

PRESSURE TRANSMITTER

Models 570 / 770 / 870



FEATURES

- All Stainless Steel Construction
- Small size — 1.5" diameter
- Exotic wetted materials available
- Watertight/submersible design
- 4-20 mA, 0-5 V, mV/Volt output
- FM, ATEX, CSA, and CE approvals available

TYPICAL APPLICATIONS

- Offshore oil rigs
- Gas compressors
- Paint spraying
- Water treatment
- Natural gas pipelines
- Polyethylene manufacture
- Rolling mills
- Stamping presses

RUGGED CONSTRUCTION

All welded construction and stainless steel surfaces makes the X70 ideal for corrosive environments. The transmitters O-ring free design ensures reliability with corrosive media. Viatran's X70 FM approved labelled units are designed to meet NEC/API Dual Seal

requirements. For most applications requiring field adjustments, Model 571 is also hermetically sealed, with magnetically coupled adjustments to eliminate contamination from liquid or gas intrusion. For the most corrosive environments, Hastelloy, Inconel, and 316 SS wetted parts are available.

OVERPRESSURE PROTECTION

Models 570, 770 and 870 all feature bonded foil strain gage sensors. The over pressure protection in this technology helps to eliminate damage to the sensors when they are exposed to transient pressure spikes. Viatran also offers isolation diaphragms and oil fills for specific application requirements.

PRESSURE MEASUREMENT SOLUTIONS

You'll find complete specifications on the following pages to help you select the right X70 transmitter for your application. Viatran offers a full line of pressure measurement products for the process control industry including a "low power" version of the X70 which draws less than 1 mA of current.

For more information, contact Viatran.



PERFORMANCE

	Full Scale Pressure Range	0-100 thru 0-100K PSIS (0-6.89 thru 0-6894 bar)
Linearity (Best Fit Straight Line)	0-100 PSI (0-6.89 bar)	±0.5%
	150-10K PSI (10.3-6.89 bar)	±0.2%
	15K-100K PSI (1034-6894 bar)	±0.25%
	Hysteresis	≤0.15% FSO
	Repeatability.....	≤0.15% FSO
Full Scale Output (FSO)	570	16 mA
	770	5 Vdc
	870	2 mV/V
	Zero and Span Balance	±1% FSO
	Long Term Stability	≤±0.25% FSO per 6 months
	Response Time.....	<2 mSec to reach 90% FSO
	Temperature Effect on Zero	≤±1% FSO per 100°F (37°C)
	Temperature Effect on Span	≤±1% FSO per 100°F (37°C)
	Compensated Temperature.....	70°F to 170°F (21°C to 76°C)
	Operating Temperature.....	-40°F to 190°F (-40°C to 87°C)
	Storage Temperature Limit	-65°F to 250°F (-53°C to 121°C)

ELECTRICAL

Supply Voltage	570/770	12 to 36 Vdc														
	870	10 Vdc nominal, 15 Vdc maximum														
Power Supply Regulation Effect	570/770	≤±0.02% FSO per Volt														
	870	Ratiometric														
Output Signal	570	4 - 20 mA														
	770	0 - 5 Vdc														
	870	2 mV/Volt (Nominal)														
Load Impedance	570	900 Ohms max at 30 Vdc														
	770	100K Ohms minimum														
Bridge Impedance	(All)	5000 Ohms nominal														
Circuit Protection	570/770	Varistor protected across the input leads for surges above 40 V and currents to 250 Amps peak with a pulse width of 20 µSecs. Reverse polarity protected.														
Insulation Resistance	570/770	>200 MegOhms to case ground														
	870	>1000 MegOhms to case ground at 50 Vdc and 70°F (21°C)														
Electrical Connection 1/2" NPT (M), 18 AWG wire, 72"															
		<table border="0" style="width: 100%; text-align: center;"> <tr> <td style="width: 33%;">570</td> <td style="width: 33%;">770</td> <td style="width: 33%;">870</td> </tr> <tr> <td>Red</td> <td>+Power/Signal</td> <td>+Power</td> </tr> <tr> <td>Black</td> <td>-Power/Signal</td> <td>+Signal</td> </tr> <tr> <td>Green</td> <td>Case ground</td> <td>-Power</td> </tr> <tr> <td>White</td> <td></td> <td>-Power/Signal</td> </tr> </table>	570	770	870	Red	+Power/Signal	+Power	Black	-Power/Signal	+Signal	Green	Case ground	-Power	White	
570	770	870														
Red	+Power/Signal	+Power														
Black	-Power/Signal	+Signal														
Green	Case ground	-Power														
White		-Power/Signal														



MECHANICAL

Pressure Connection	0-50 thru 0-15K PSI	1/4" - 18 NPT Female (0-3.3 thru 0-1034 bar)
	0-20K thru 0-50K PSI	1/4" F250-C High Pressure Tube (0-1378 thru 0-3447 bar)
	0-60K thru 0-100K PSI	5/16" F312C High Pressure Tube (0-4136) thru 0-6894 bar)
Proof Pressure	0-100 thru 0-15K PSI	1.5 times FSPR or 20K PSI (1378 bar), (0-6.8 thru 0-1034 bar) whichever is less
	0-20K thru 0-100K PSI	1.2 times FSP (0-1378 thru 0-6894 bar)
Burst Pressure	0-100 thru 0-15K PSI	≥ 2.3 to 5 times FSPR dependent on (0-6.8 thru 0-10342 bar) sensor
	0-20K thru 0-100K PSI	≥ 1.5 times FSPR or 125K PSI (8618 bar) (0-1378 thru 0-6894 bar) whichever is less
Mounting.....	Supported by process piping or optional mounting bracket	

MATERIALS OF CONSTRUCTION

Enclosure	0-100 thru 0-15K PSI.....15-5 PH and 316 stainless steel (0-6.8 thru 0-1034 bar)
	0-20K thru 0-100K PSI.....316 SST and PH 13-8 Mo SST (0-1378 thru 0-6894 bar)
Wetted Parts	0-100 thru 0-15K PSI.....15-5 PH stainless steel (0-6.8 thru 0-1034 bar)
	0-20K thru 0-100K PSI.....PH 13-8 Mo SST (0-1378 thru 0-6904 bar)
	Shock Limitation.....100 G's
	Weight.....24 oz. (0.680 kilograms)
	Identification.....Laser etched onto body
	Enclosure.....Classification NEMA 4X

CERTIFICATIONS (CONSULT FACTORY FOR AVAILABLE OPTIONS)

USA	Intrinsic Safety: Class I, II, III, Division 1, Groups A-G, Class I, Zone 0, AEx ia IIC, T4 at Ta=80°C, T5 at Ta=40°C Entity, NEMA Type 4X Hazardous Locations Explosion Proof: Class I, II, III Division 1, Groups A-G, AEx d IIC, T5 at Ta=88°C NEMA 4X Hazardous Locations Nonincendive: Class I, II, III Division 2, Groups A,B,C,D,F,G, Class I, Zone 2, Group IIC, T4 at Ta=80°C, T5 at Ta=40°C, NEMA Type 4X Hazardous Locations
CANADA	Intrinsic Safety: Ex ia IIC; Class I, Zone 0; Class I, II, III, Groups A-G; NEMA Type 4, T4 at Ta=80°C, T5 at Ta=40°C Explosion Proof: Class I, II, III, Groups A-G Hazardous Locations
EUROPE	Intrinsic Safety:  II 1G, Ex ia IIC, -20°C, Ta <40°C, Flameproof:  II 2 G Ex d IIC, T6 (-20°C ≤ Ta ≤ 40°C) Nonincendive:  II G Ex nA II, T4 Gc (-20°C ≤ Ta ≤ 80°C) (770/870) EMC Directive 2004/108/EC EN 61326-1:2006 PED Directive 97/23/EC

OPTIONS

Y()	Alternate pressure ports performance options
DF	Bleed port (10K PSI and below)
DG	Improved temperature compensation (<5%/100°F for zero/span)
DH	Special range
DM	Modified output (0-10 Vdc, 770 only)
DQ	Cleaning for oxygen service
EA	Special calibration run
JJ	Direct mount indicator with explosion proof housing
JS	Direct mount indicator
ME	CSA explosion proof label (570/870)
MR	Modified electrical damping (570)
NG	ATEX flameproof label
NH	Customer specified identification
NJ	CE label
NK	ATEX intrinsic safety label (570)
NX	CSA intrinsic safety label (570)
NY	FM explosion proof label
NZ	FM nonincendive label
PW	1/8 DIN digital indicator (consult factory)
QA	316 stainless steel wetted parts
QB	Inconel (X-750) wetted parts
QC	Hastelloy (C-276) wetted parts
TF	FM intrinsic safety label
TK	ATEX nonincendive label

Note: Application of some available options may affect standard performance. Consult your Viatran Representative for details.

ACCESSORIES

- Mounting bracket
- Conduit connection box
- Loop powered digital indicator

FOR RANGES 0-15K PSI

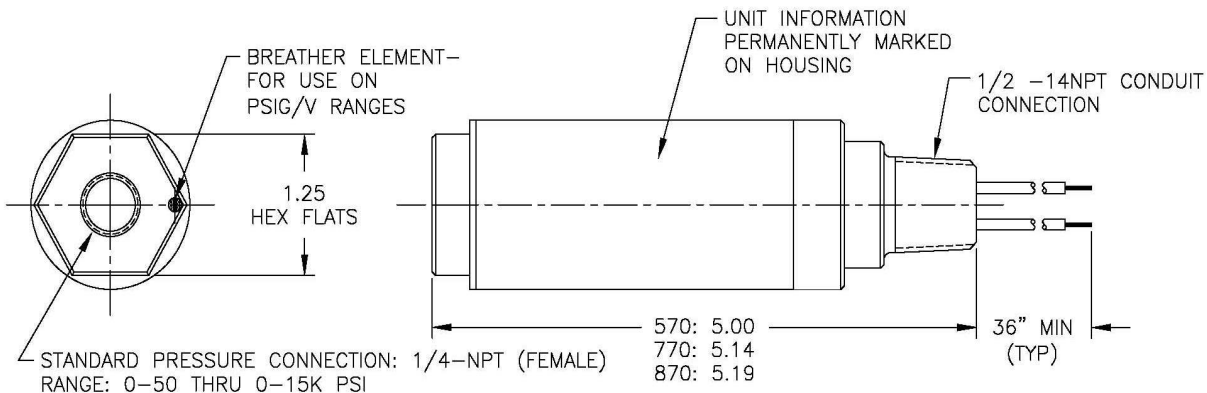

FOR RANGES 20K-100K PSI

